

MILL VALLEY FIRE DEPARTMENT



Prepared by *JDamb*
Jeff Davidson, Battalion Chief/Fire Marshal
Approved by *Greg Moore*
Gregory R. Moore, Fire Chief

Fire Protection Standard 216

LADDER TRUCK

Date: 1-11-11

Revision: 2

Page: 1 of 1

This Standard has been developed pursuant to Chapter 5 of the California Fire Code and Chapter 4 of the International Wildland Urban Interface Code, both as adopted by ordinance by the City of Mill Valley. The purpose of the standard is to provide specific criteria and dimensions in designing fire apparatus turn around for commercial and residential developments.

Gross Vehicle Weight: 69,000 pounds
Width – 9 feet door to door. 17 feet with outriggers extended
Ladder Truck Turn Radius Example

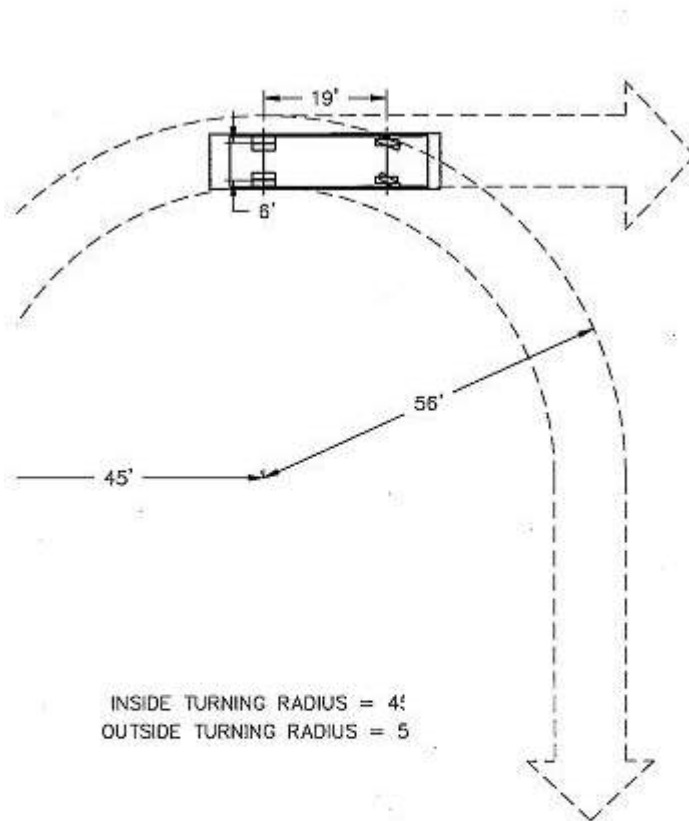

INSIDE TURNING RADIUS = 4'
OUTSIDE TURNING RADIUS = 5'

GRAPHIC SCALE

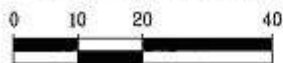

(IN FEET)
1 inch = 20 ft.